



3156 & 3156HR BARIATRIC CHAIRS OWNER'S MANUAL



TOOLS NEEDED:

1. Two 9/16-inch wrenches

Note: A 14 mm wrench can also be used as an alternative.

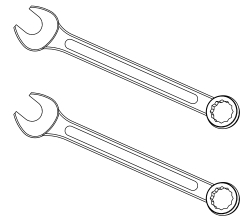

2. One small mallet



3. Small board (recommended)



4. One 5/16-inch Allen wrench

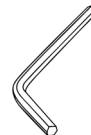

Adjustment Instructions

Chair Height

****TO MAKE ADJUSTMENTS, A PARTNER IS NEEDED**

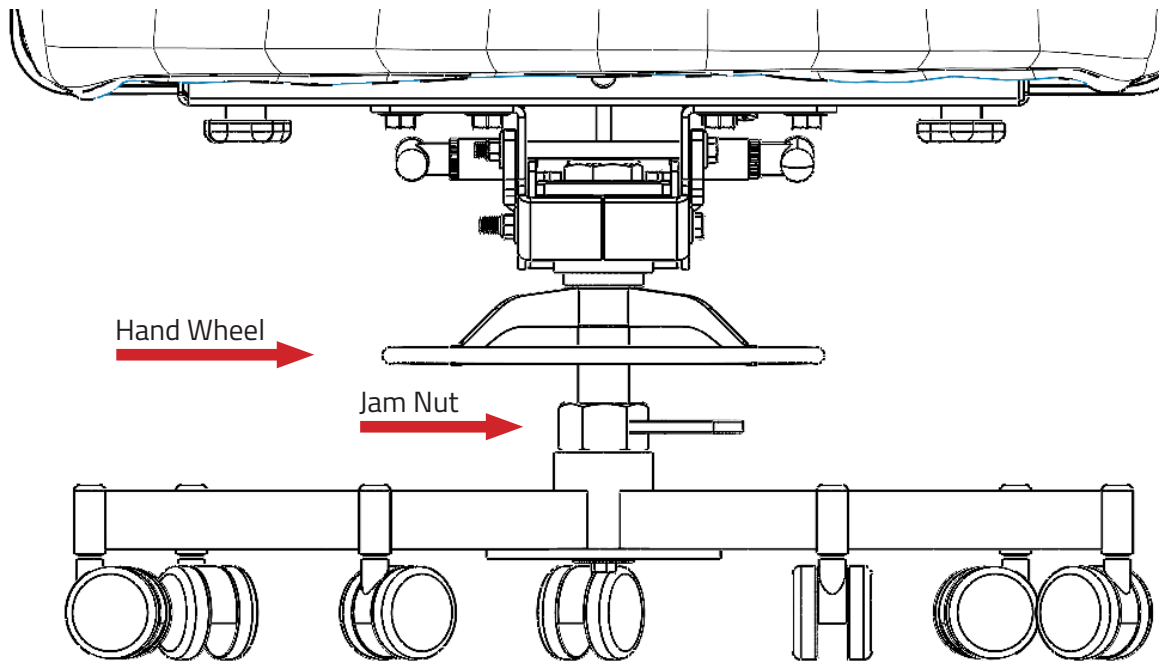

Height Adjustment

1. Loosen the large jam nut by turning counterclockwise.

Tip: Place a small board against the arm, then gently tap with a small mallet to loosen (counterclockwise).

2. Rotate the handwheel to move the chair up or down.
3. Finish by retightening the jam nut against the base.



Adjustment Instructions

Chair Seat Depth

Chair Seat Depth Adjustment

1. Identify the tilt-lock bolt and nut located on either side of the tilt mechanism.
2. Using both of the 9/16 inch (14 mm) wrenches, place one on the bolt head and one on the nut side.
3. To loosen, use the wrench to turn the nut counterclockwise, then slide the tilt-lock bolt out of the tilt mechanism.

CAUTION: Have a partner hold the seat in place while removing the tilt-lock bolt, this will prevent sudden chair movement.

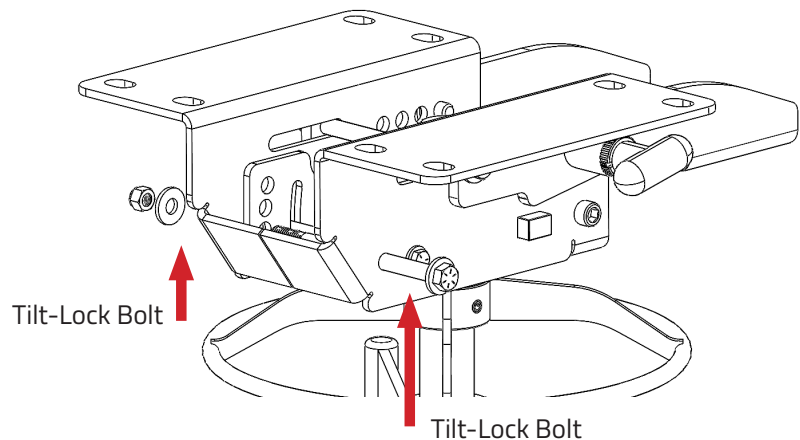

Chair Seat Depth Adjustment

4. Disengage the lock out pin (black handle with silver base) by pulling out and turning 90° to lock the pin in an open position.
5. Next, disengage the spring pin (black handle with black base) by pulling outward.
6. Slide the seat forward or backward to the desired chair seat depth.

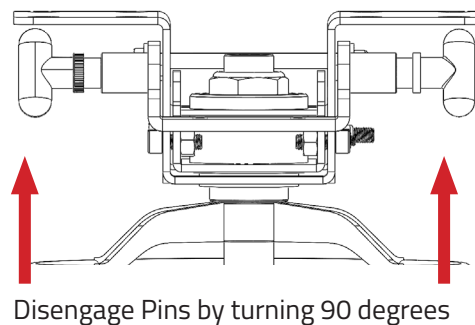
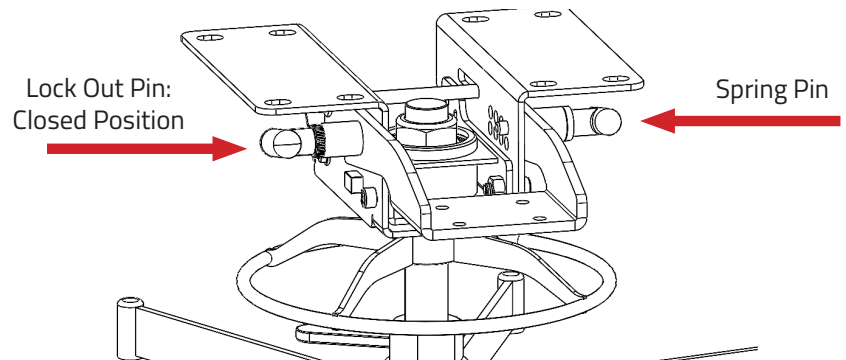

Adjustment Instructions

Chair Seat Depth

Chair Seat Depth Adjustment Continued

7. To set the seat depth, reengage both the spring pin and the lock out pin, making sure they are in their original position and in full contact with the base.
8. Slide the tilt-lock bolt back into the tilt mechanism.
9. Replace the washer and tilt-lock nut at the end of the bolt.
10. Secure the seat depth adjustment by using both 9/16 inch (14 mm) wrenches to tighten the tilt-lock nut until secure on the bolt.

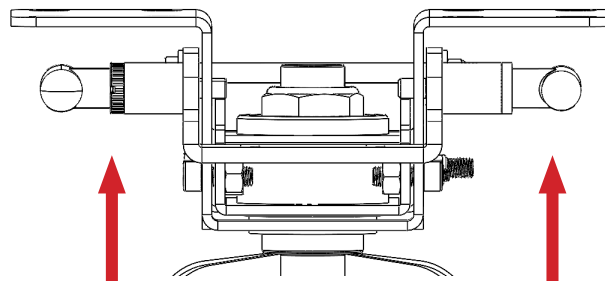
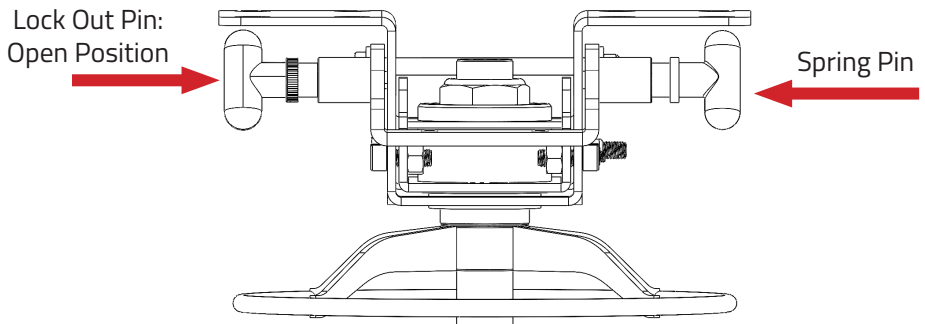

Be sure Pins are flat and in starting position

Adjustment Instructions

Seat Tilt

Chair Seat Tilt Adjustment

1. Using the 5/16 inch Allen wrench, loosen (but don't remove) the socket head bolts located on the left and right sides towards the back of the tilt mechanism. There will be one bolt on each side (see picture).
2. Identify the tilt-lock bolt and nut, located on either side towards the front of the tilt mechanism.
3. Using both 9/16 inch (14 mm) wrenches, remove the tilt-lock nut and washer, then slide the tilt-lock bolt all the way out of the tilt mechanism.

CAUTION: Have a partner hold the seat in place while removing the tilt-lock bolt, this will prevent sudden chair movement.

Step 1

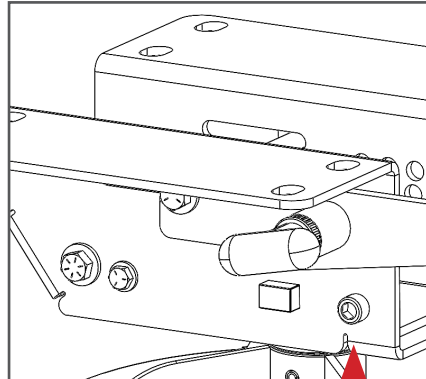

Socket Head Bolt

Step 2

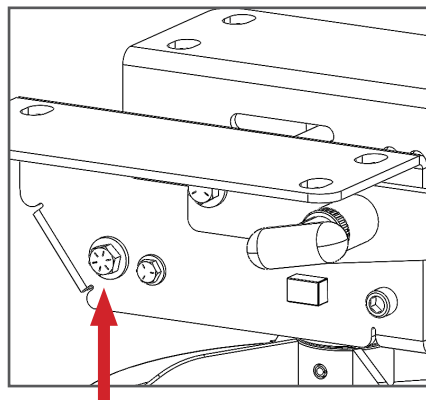

Tilt-Lock Bolt & Nut

Step 3

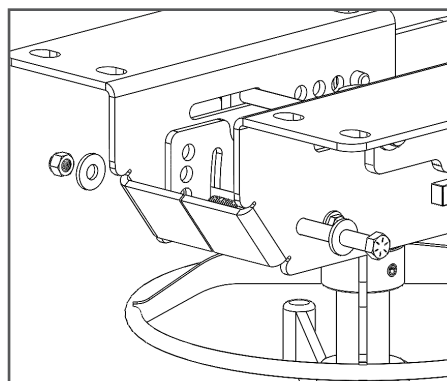

Adjustment Instructions

Seat Tilt

Chair Seat Tilt Adjustment Continued

4. Tilt the seat to one of the three recline positions as indicated by lining up the holes where the tilt-lock bolt was removed.
5. When desired tilt-lock position holes are aligned, slide the tilt-lock bolt back into place.
6. Replace the washer and tilt-lock nut on the end of the tilt-lock bolt.
7. Using both of the 9/16 inch (14 mm) wrenches, securely tighten the tilt-lock nut onto the tilt-lock bolt.
8. Finish by using the 5/16 inch Allen wrench to tighten the two socket head bolts that were loosened in Step 1.

Step 4

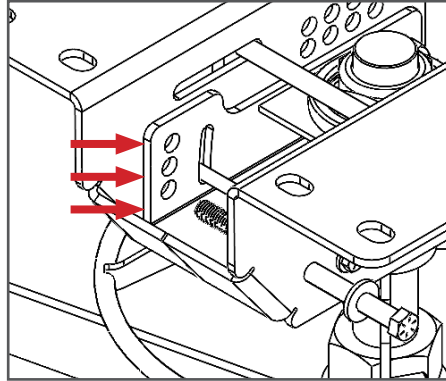

Step 5

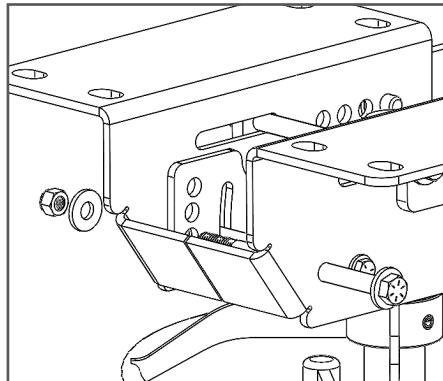

Steps 6 & 7

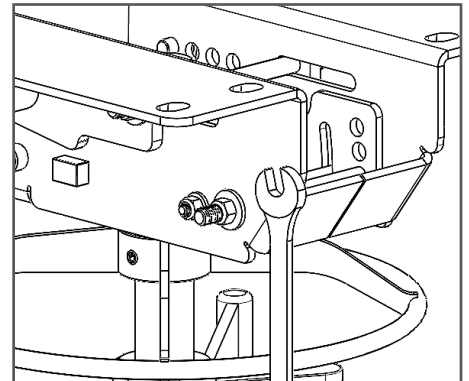

Step 8

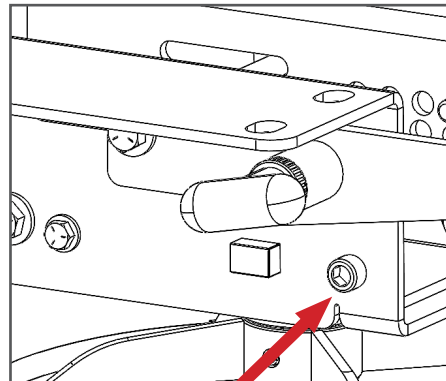

Socket Head Bolt

Cleaning Guide

ALWAYS PRETEST ANY CLEANING METHOD IN AN INCONSPICUOUS OR UNEXPOSED AREA.

Consider purchasing a washable slipcover if sharing the chair with others.

ALTERNATIVE LEATHER

Basic maintenance is recommended at least once a week to extend the material's lifespan.

Option 1: Cleaning Wipes

1. Approved cleaning wipes:
 - [Clorox Healthcare - Bleach Germicidal Wipes](#)
 - [Clinell Universal Cleaning Wipes](#)

Option 2: Diluted Liquid

1. Clean the whole surface in circular motions using pH neutral liquid hand soap and water (1 part soap to 9 parts water).
2. Rinse and wipe with a clean damp white cloth to get rid of any excess soap.
3. Repeat as needed and then let dry.

Option 3: Bleach solution:

1. Use 0.5% concentration, which can be prepared as one part bleach per 10 parts of water.
2. Rinse and wipe with a clean, damp, white cloth to get rid of any excess.
NOTE: To prolong the life of the material, disinfectants should be rinsed off after each use. The misuse of disinfectants is the major source of surface deterioration.
3. Allow the chair to dry thoroughly.

DO NOT USE solvents like paint thinner, Varsol®, acetone, whiteners, waxes, silicones, detergents, and/or cleaning products that are not pH neutral. Abrasive cleaning tools such as plastic or wire sponges or hard-bristle brushes can permanently damage alternative leather. Never use alcohol or wipes that contain alcohol.

LEATHER

For basic maintenance: Occasionally dust with a clean cloth, or gently wipe the leather with a clean, damp cloth to remove accumulated soil and allow it to air dry. Leather conditioners and protectants, such as those by Leather Master® can be used as directed.

For spills:

1. Blot immediately using a clean absorbent cloth or paper towel.
2. For a more thorough cleaning we recommend: [Cortina Leathers, Universal Cleaner High-Tech Wipes](#) or a solution of lukewarm water and a mild cleaner, such as Ivory® soap or Woolite®.
 - a. Dampen a clean white cloth and gently wipe the affected area using a circular motion.
 - b. Rinse completely with a clean cloth to ensure all cleaner is removed.
 - c. Dry with a clean dry cloth, and allow to completely air dry.
 - d. Repeat the cleaning process as needed, allowing the leather to dry between applications.

While it is possible to remove many deep stains and soiling from semi-aniline and pigmented leathers, it may not be possible to remove all stains from this natural product.

Alcohol and wipes that contain alcohol are not recommended.

DO NOT USE bleach, ammonia, or any harsh cleaners. These types of cleaners compromise the natural leather and dye.

Cleaning Guide

STACCATO

For regular maintenance, please following the steps below:

1. Vacuum the chair.
2. Use an upholstery brush and spot treat to remove stains.
3. Fill a handheld steam cleaner with water and steam your fabric chair. You can use detergents with some steam cleaners; this will help remove strong odors.
4. Allow the chair to dry thoroughly.
5. Spray the seat with a fabric refresher to complete the deodorizing process.

DO NOT oversaturate the surface with water or other cleaning solutions. This can cause mold and foul odors. Avoid excessive scrubbing as this will set in stains.

CORDURA

- Soil may be removed with spray cleaner or detergent and water.
- Oil or grease should first be treated with a dry cleaning solvent followed by a spray cleaner or detergent and water.

DO NOT USE chlorine or bleach based cleansers.

ESD FABRIC

Clean with water-based cleanser or mild dry cleaning solvent.

DO NOT USE products containing bleach. Never use heat. Heat can set stains. Do not saturate the surface with water or other cleaning solutions. Soak up any excess moisture immediately.

CASTERS

1. Pull out any large clumps of hair or dirt that are lodged in the wheel.
2. Vacuum the casters using the appropriate attachment or blow out any dirt with compressed air.
3. Clean once every six months.

Learn More About Your Chair



Need more information on your new chair?

Scan the QR code to visit our maintenance and cleaning directory. Here you'll find video content and more tools on how to properly use and care for your new Concept Seating chair.

For further assistance, please contact us at info@conceptseating.com.



24/7 Intensive Use Seating Warranty Policy

Laacke and Joys Company LLC warrants, to the original purchaser of Concept Seating 24/7 seating products, that the steel seat frame and the steel portion of the seven-leg base shall be free from product failure under normal 24/7 use for the lifetime of the product.

All other components of the Concept Seating 24/7 Intensive Use chairs are warranted against product failure (as defined solely by Laacke and Joys Company LLC; see exceptions below) for a period of 6 years from the original date of manufacture. All warranty claims will be remedied via the method which is most appropriate for each individual situation as determined solely by Laacke and Joys Company LLC.

The warranty further covers:

- Shipping costs on approved warranty claims within the United States.
- Purchased parts for 2 years from the sales order date.

Examples of what the warranty does not cover:

- Lost parts, abuse, alteration, misuse, or negligence of the chair or its components at the sole discretion of Laacke and Joys Company LLC.
- Failure to follow the manufacturer's assembly, operating and/or preventative maintenance instructions, either by purchaser or third-party.
- Use of models 3142, 3142r1, 3120, 3122, 3150(HR), or 3152(HR) by persons weighing over 550 pounds, or the use of model 3156(HR) by persons weighing more than 800 pounds
- Products exposed to extreme environmental conditions such as water, smoke, excessive humidity, corrosive materials, or improper storage (products should be stored in a dry, climate controlled environment.).
- Products sold by unauthorized dealers.
- Minor variations of color in cover materials against sample swatches or previous purchases.
- Minor irregularities of color, surface, grain, texture, wrinkles or stretch marks in natural leather.
- Fading or discoloration over time or due to soiling, staining, or dye-transferring from clothing.
- Labor costs associated with the installation of warrantied parts.
- Any damage not noted on the freight bill before signing at time of delivery

In no event shall the total liability of manufacturer resulting from product failure, as damages or otherwise, exceed the purchase price of the product. Neither Laacke and Joys Company LLC nor their authorized dealers under any circumstances shall assume responsibility for loss of time, inconvenience, commercial loss, expenses for travel, lodging, or damage to personal property, loss of revenue, or incidental or consequential damages.

Laacke and Joys Company LLC reserves the right to make changes or improvements in the design of Concept Seating products without obligation to make corresponding changes or improvements in previously manufactured Concept Seating products.

All warranty claims must be submitted using the online claim form at www.conceptseating.com/resources/warranty-claim/.

This is the exclusive and complete warranty made by Laacke and Joys Company LLC with respect to the Concept Seating 24/7 Intensive Use seating products. No person whatsoever is authorized to make any representation, warranty, or promise on behalf of the manufacturer. Laacke and Joys Company LLC makes no other expressed warranties and disclaims any and all implied warranties. The remedies set forth above pertaining to repair or replacement of parts or materials are exclusive of all other remedies. Dealer makes no warranty on his or her own.



**Concept
Seating®**

We Give a Sit

ConceptSeating.com | (800) 892-5563