



3150, 3150HR, 3152, 3152HR CHAIRS & STOOLS OWNER'S MANUAL



TOOLS NEEDED:

Two half-inch wrenches

NOTE: A 13 mm wrench can also be used as an alternative.

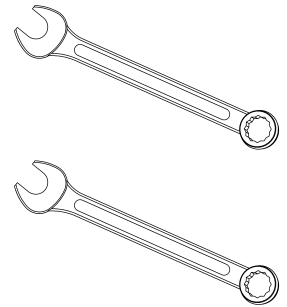

PARTS LIST

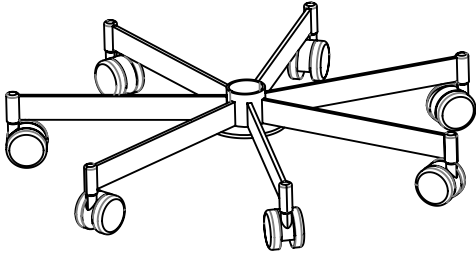

7-Leg Base with Attached Casters (1)

(Note: Shown is our Standard chair base, but the Standard or Two-Step Stool base may also be used)

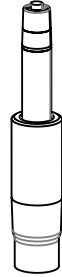

Gas Cylinder (1)

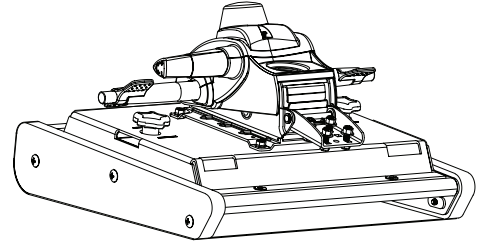

Seat Bottom (1)



Grease Packet (1)

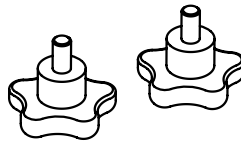

Handwheels (2)

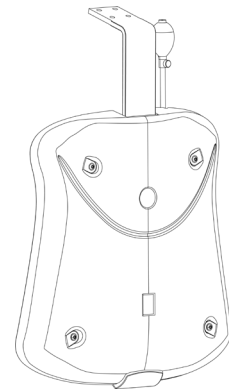

Seat Back (1)

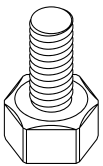

Bolts (4)

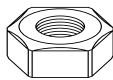

Nuts (4)



Washers (8)

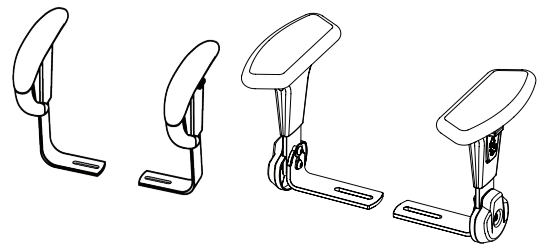

C-Loop OR Pivot Armrests (2)

Assembly Instructions

Assembling the Base

1. Open the base box, this is the smaller of the two boxes. Set the base on the floor.
2. Unwrap the cylinder from the plastic bag. Remove all packaging from the cylinder.
3. Open the grease packet located in the cylinder bag, and place a line of grease around the cylinder, 3 inches (7.62 cm) from the bottom.

NOTE: The top is the silver portion. The black portion is the bottom.

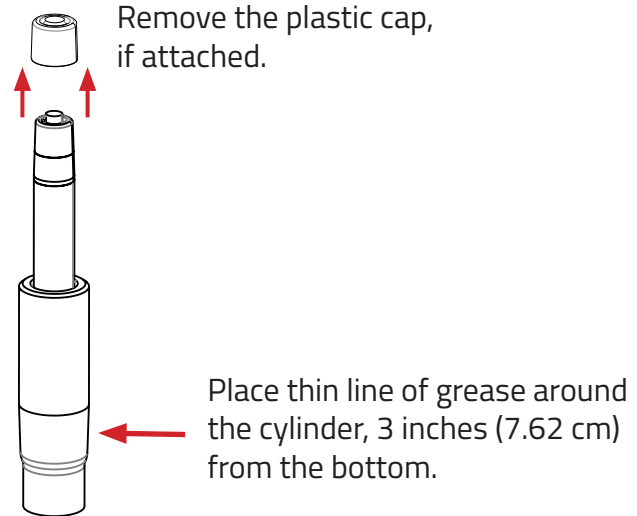

Assembling the Base Cont.

4. Insert the bottom of the cylinder into the base.
5. Place another line of grease around the cylinder, approximately a half inch (1.27 cm) from the top.

NOTE:

- These instructions are the same for all base types.
- DO NOT POUND THE CYLINDER INTO THE BASE.

Place thin line of grease around the cylinder, a half inch (1.27 cm) from the top.

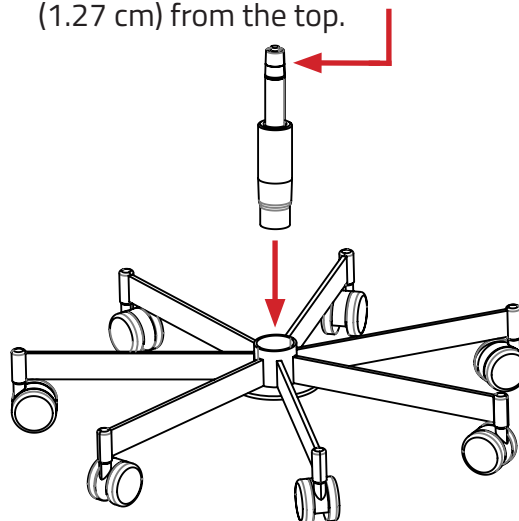

Base Options

Halfring Base



Standard Stool Base



Two-Step Stool Base



Assembly Instructions

Assemble the Seat

1. Open the chair box. This is the larger of the two boxes and may require a team lift. Take the seat back out of the box and remove the plastic bag. Locate the small red bag attached to the cardboard supports and set it aside. The red bag contains the hardware you will need for assembly.
2. Remove the cardboard filler. Take the seat bottom out of the box and remove the plastic bag.

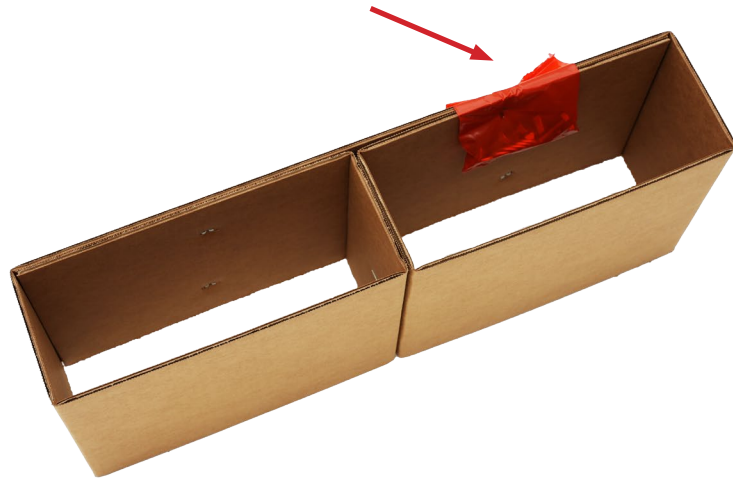

Assemble the Seat Cont.

3. Place the seat bottom on the floor with the cushion side down. The U-channel should face towards you.
4. With the seat back cushion side down, slide the J-bar into the seat bottom U-channel. You may need to prop both sections up so the J-bar slides in easily.

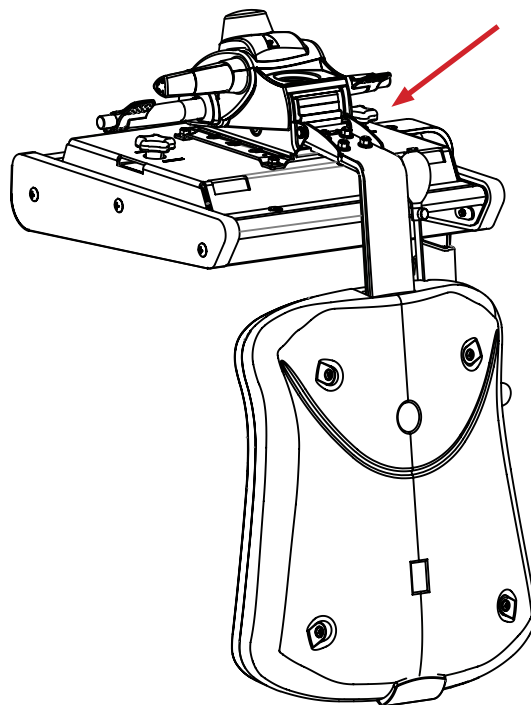

Assembly Instructions

Assemble the Seat Cont.

5. Line up the four holes. Place one washer on the bolt head side and thread through the pre-machined hole. Then, place an additional washer and nut on the opposite side of the bolt head.
6. Use one half-inch (or 13 mm) wrench to hold the bolt in place. Then use the second half-inch wrench to tighten the bolt. Repeat steps 5 and 6 until all four bolts are secured.

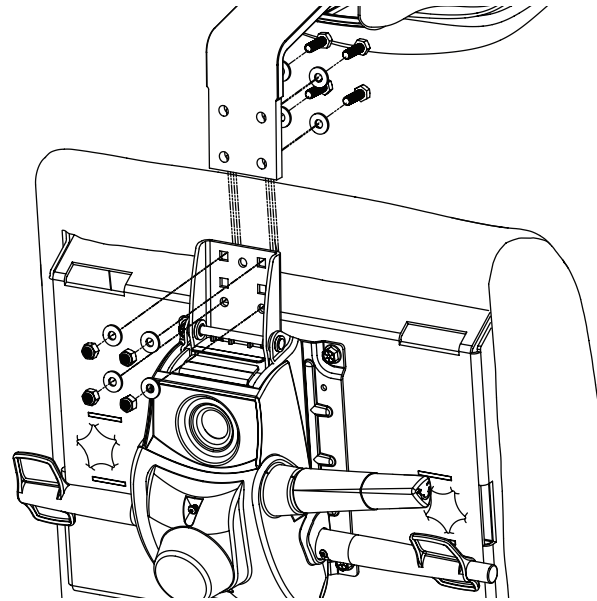

*Tighten the top two holes first for ease of assembly.

Assemble the Seat Cont.

7. Unscrew the two handwheels. They are located on the left and right side of the bottom of the seat. Set handwheels aside for later use.

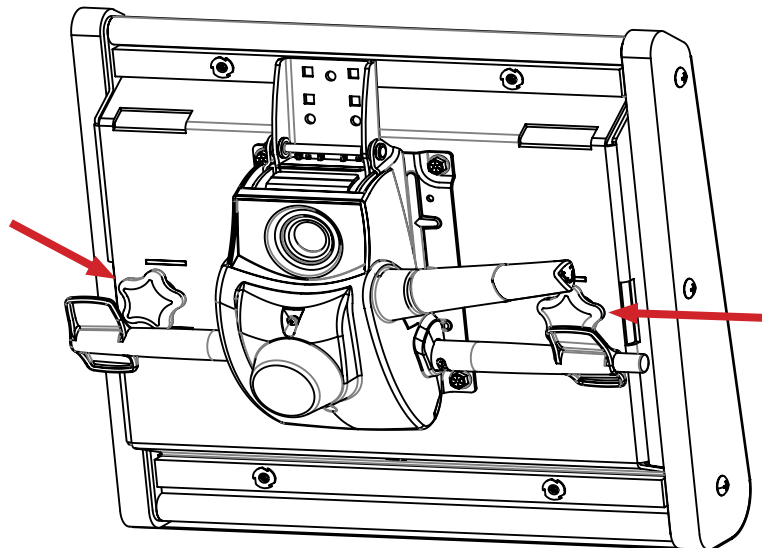

Assembly Instructions

Assemble the Seat Cont.

8. Next, slide the cylinder with attached base into the machined hole of the tilt mechanism. The cylinder fits into the tilt mechanism as a compression fit. No additional assembly is required.
9. Bring the chair upright.

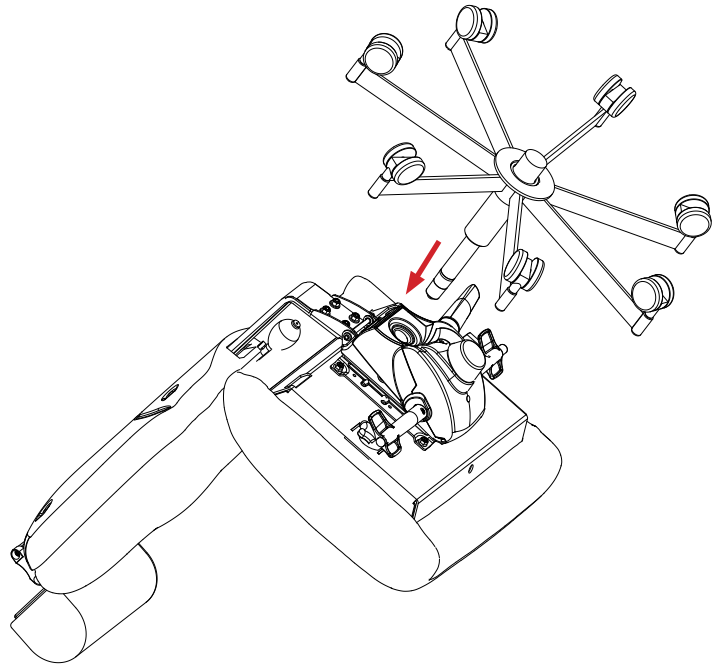

Attach the Armrest to the Chair

1. Open the armrest box. This is located in the chair box.
2. Slide armrest into the machined armrest slot. Repeat for other side of chair. For C-loop arms, the closed section should go to the front of the chair. Pivot arms are universal and may be placed on either side of chair.

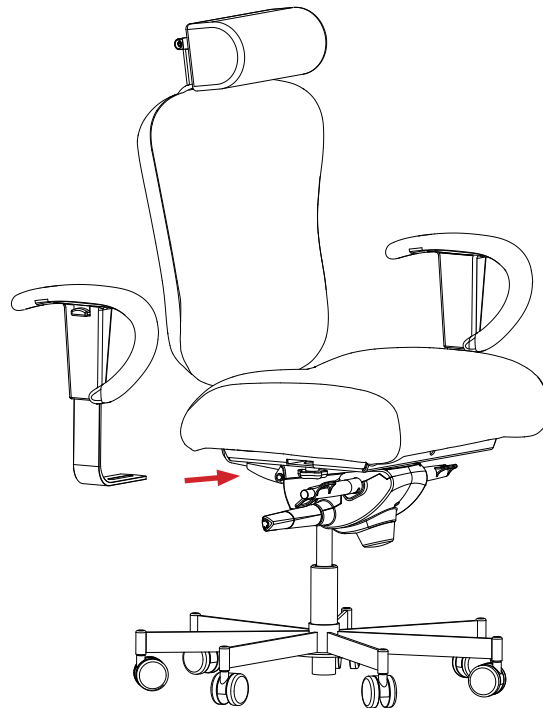

Assembly Instructions

Attach the Armrests to the Chair Cont.

- Carefully align the handwheels and tighten until snug. Do not over tighten. If the handwheel screws in crooked, stop. Remove the handwheel and start over. This will prevent cross threading.
- Sit in the chair and make sure all the adjustments work properly.

Enjoy!

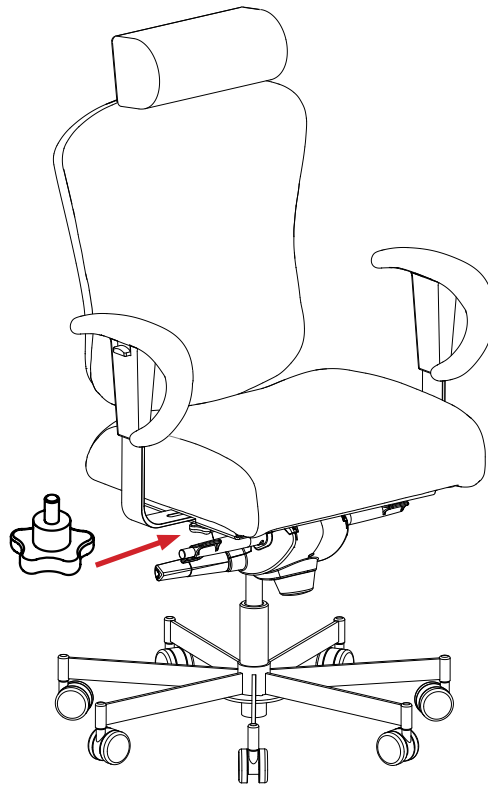

Learn More About Your Chair



Need more information on your new chair?

Scan the top QR code to view our YouTube playlist that shows informative videos, including step-by-step assembly instructions on the 3150, 3150HR, 3152, & 3152HR Chair.



Need more information on your new chair?

Scan the QR code to visit our maintenance and cleaning directory. Here you'll find video content and more tools on how to properly use and care for your new Concept Seating chair.

For further assistance, please contact us at info@conceptseating.com.

Adjustment Guide

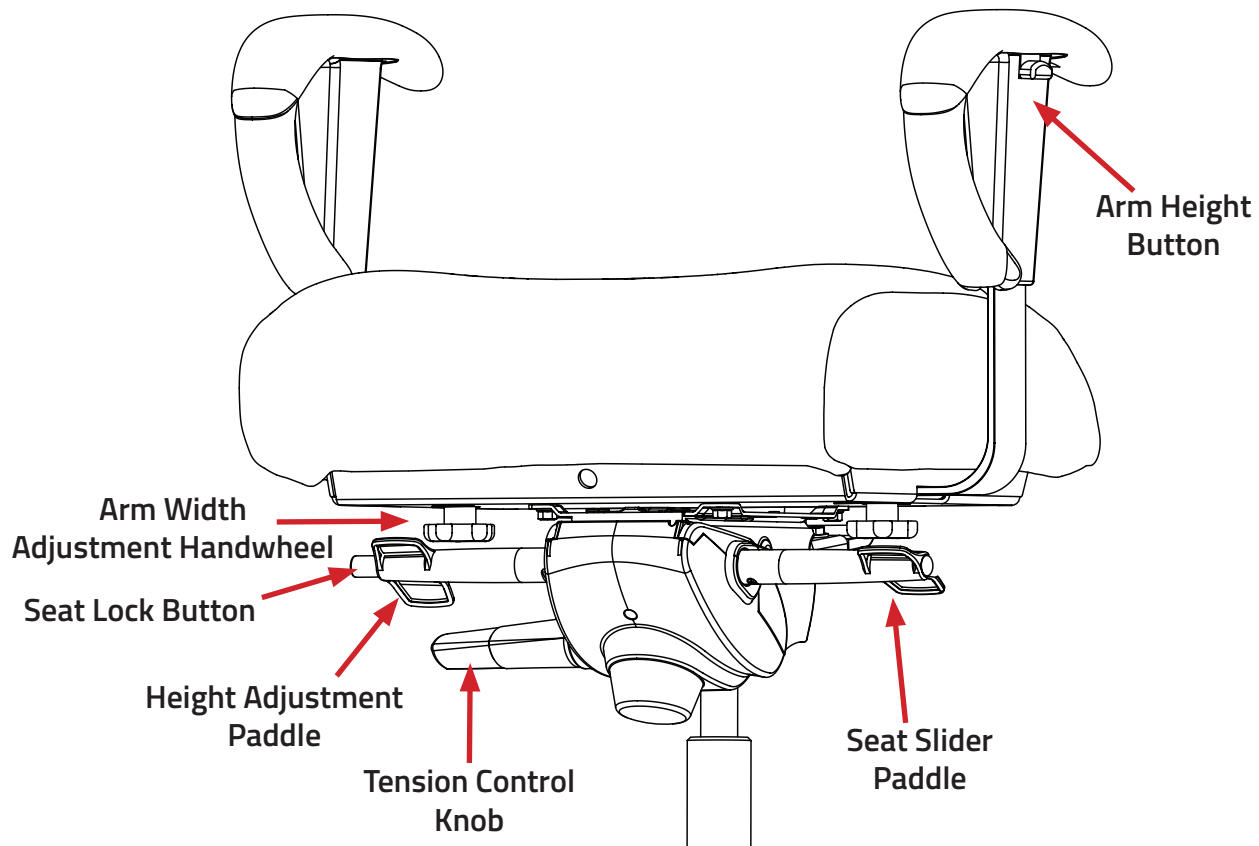

Height Adjustment Paddle

Twist the paddle to adjust the height up or down. To move down, use your body weight to lower the chair. To move up, stand up and let the chair raise.

Seat Position Lock Button

Press the button to lock it in a recline position; press again to unlock.

Tension Control Knob

This feature adjusts the amount of force needed to adjust the backrest. Twist clockwise to increase the strength of tension for your chair. Twist counterclockwise to decrease the tension.

Seat Slider Paddle

Twist the paddle to adjust the seat bottom, forward to backward.

Arm Height Button

To adjust the height of the armrest, locate the button underneath the armrest pad. Push the button in to raise or lower the arm. The button location is the same for both C-loop and pivot arms.

Arm Width Adjustment Handwheel

Turn the handwheel clockwise to loosen. Pull out the arm rest to desired width. Turn the handwheel counterclockwise to tighten and secure the armrest in place. Adjust for both right and left sides.

Adjustment Guide

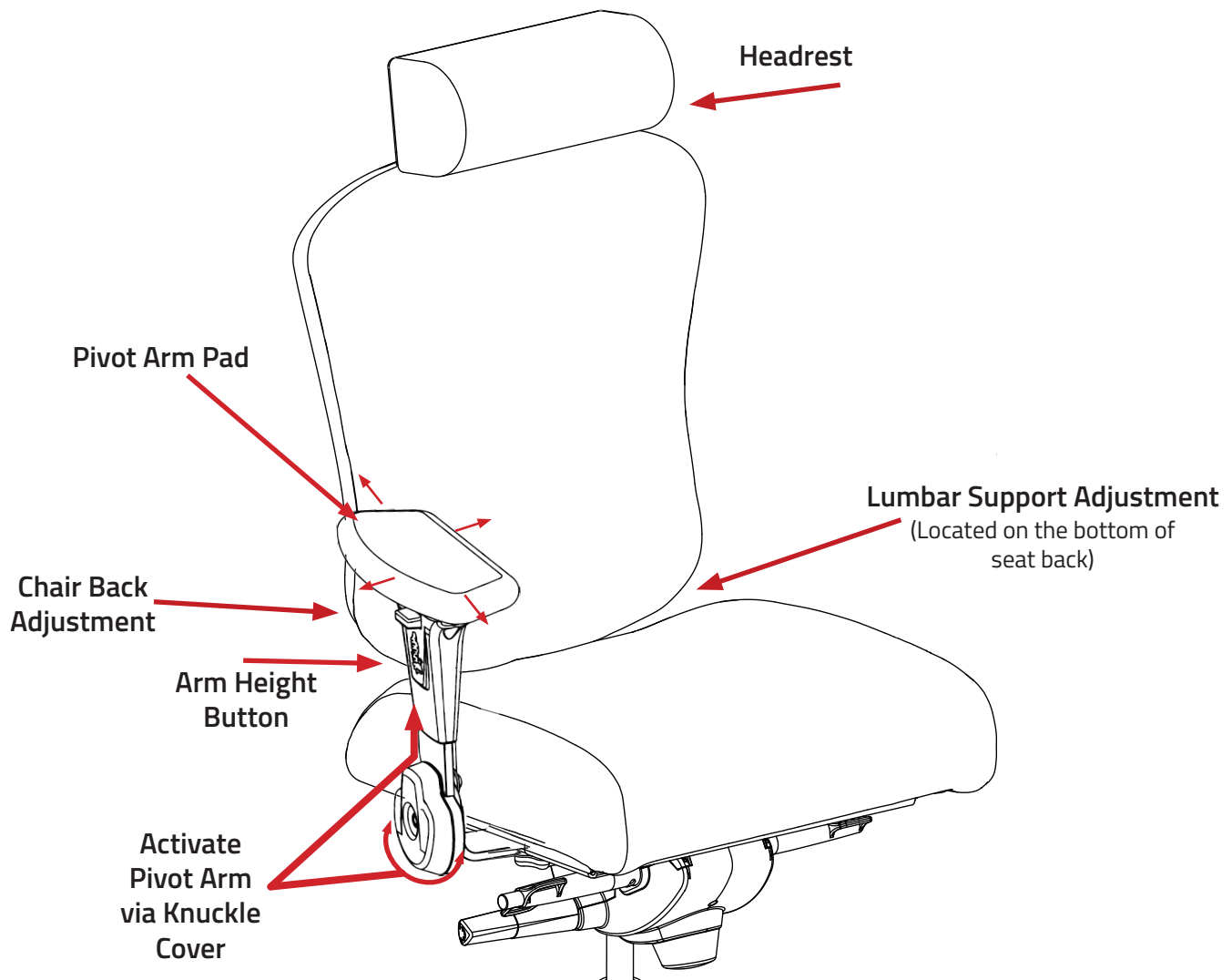

Lumbar Support Adjustment

Making sure the valve on the lumbar bulb is closed, pump the bulb to desired inflation. To deflate, twist the valve counterclockwise.

Chair Back Adjustment

Place hands on the bottom of chair back and lift up to the desired position. There are five ratchet positions. The sixth ratchet position will return it to the bottom.

Headrest

Angle headrest cushion to the desired location either as a headrest, neckroll, or move it out of the way. To adjust the height, lift the headrest up. There are five ratchet positions. The sixth ratchet position will return it to the bottom.

Pivot Arm Pad

With your hand, move the arm pad forward or backward and left or right.

Activate Pivot Arm

Holding the knuckle cover, raise pivot arm until the arm releases from the bracket. Pivot the arm front or back to the desired location.

Cleaning Guide

ALWAYS PRETEST ANY CLEANING METHOD IN AN INCONSPICUOUS OR UNEXPOSED AREA.

Consider purchasing a washable slipcover if sharing the chair with others.

ALTERNATIVE LEATHER

Basic maintenance is recommended at least once a week to extend the material's lifespan.

Option 1: Cleaning Wipes

1. Approved cleaning wipes:
 - [Clorox Healthcare - Bleach Germicidal Wipes](#)
 - [Clinell Universal Cleaning Wipes](#)

Option 2: Diluted Liquid

1. Clean the whole surface in circular motions using pH neutral liquid hand soap and water (1 part soap to 9 parts water).
2. Rinse and wipe with a clean damp white cloth to get rid of any excess soap.
3. Repeat as needed and then let dry.

Option 3: Bleach solution:

1. Use 0.5% concentration, which can be prepared as one part bleach per 10 parts of water.
2. Rinse and wipe with a clean, damp, white cloth to get rid of any excess.
NOTE: To prolong the life of the material, disinfectants should be rinsed off after each use. The misuse of disinfectants is the major source of surface deterioration.
3. Allow the chair to dry thoroughly.

DO NOT USE solvents like paint thinner, Varsol®, acetone, whiteners, waxes, silicones, detergents, and/or cleaning products that are not pH neutral. Abrasive cleaning tools such as plastic or wire sponges or hard-bristle brushes can permanently damage alternative leather. Never use alcohol or wipes that contain alcohol.

LEATHER

For basic maintenance: Occasionally dust with a clean cloth, or gently wipe the leather with a clean, damp cloth to remove accumulated soil and allow it to air dry. Leather conditioners and protectants, such as those by Leather Master® can be used as directed.

For spills:

1. Blot immediately using a clean absorbent cloth or paper towel.
2. For a more thorough cleaning we recommend: [Cortina Leathers, Universal Cleaner High-Tech Wipes](#) or a solution of lukewarm water and a mild cleaner, such as Ivory® soap or Woolite®.
 - a. Dampen a clean white cloth and gently wipe the affected area using a circular motion.
 - b. Rinse completely with a clean cloth to ensure all cleaner is removed.
 - c. Dry with a clean dry cloth, and allow to completely air dry.
 - d. Repeat the cleaning process as needed, allowing the leather to dry between applications.

While it is possible to remove many deep stains and soiling from semi-aniline and pigmented leathers, it may not be possible to remove all stains from this natural product.

Alcohol and wipes that contain alcohol are not recommended.

DO NOT USE bleach, ammonia, or any harsh cleaners. These types of cleaners compromise the natural leather and dye.

Cleaning Guide

STACCATO

For regular maintenance, please following the steps below:

1. Vacuum the chair.
2. Use an upholstery brush and spot treat to remove stains.
3. Fill a handheld steam cleaner with water and steam your fabric chair. You can use detergents with some steam cleaners; this will help remove strong odors.
4. Allow the chair to dry thoroughly.
5. Spray the seat with a fabric refresher to complete the deodorizing process.

DO NOT oversaturate the surface with water or other cleaning solutions. This can cause mold and foul odors. Avoid excessive scrubbing as this will set in stains.

CORDURA

- Soil may be removed with spray cleaner or detergent and water.
- Oil or grease should first be treated with a dry cleaning solvent followed by a spray cleaner or detergent and water.

DO NOT USE chlorine or bleach based cleansers.

ESD FABRIC

Clean with water-based cleanser or mild dry cleaning solvent.

DO NOT USE products containing bleach. Never use heat. Heat can set stains. Do not saturate the surface with water or other cleaning solutions. Soak up any excess moisture immediately.

CASTERS

1. Pull out any large clumps of hair or dirt that are lodged in the wheel.
2. Vacuum the casters using the appropriate attachment or blow out any dirt with compressed air.
3. Clean once every six months.



24/7 Intensive Use Seating Warranty Policy

Laacke and Joys Company LLC warrants, to the original purchaser of Concept Seating 24/7 seating products, that the steel seat frame and the steel portion of the seven-leg base shall be free from product failure under normal 24/7 use for the lifetime of the product.

All other components of the Concept Seating 24/7 Intensive Use chairs are warranted against product failure (as defined solely by Laacke and Joys Company LLC; see exceptions below) for a period of 6 years from the original date of manufacture. All warranty claims will be remedied via the method which is most appropriate for each individual situation as determined solely by Laacke and Joys Company LLC.

The warranty further covers:

- Shipping costs on approved warranty claims within the United States.
- Purchased parts for 2 years from the sales order date.

Examples of what the warranty does not cover:

- Lost parts, abuse, alteration, misuse, or negligence of the chair or its components at the sole discretion of Laacke and Joys Company LLC.
- Failure to follow the manufacturer's assembly, operating and/or preventative maintenance instructions, either by purchaser or third-party.
- Use of models 3142, 3142r1, 3120, 3122, 3150(HR), or 3152(HR) by persons weighing over 550 pounds, or the use of model 3156(HR) by persons weighing more than 800 pounds
- Products exposed to extreme environmental conditions such as water, smoke, excessive humidity, corrosive materials, or improper storage (products should be stored in a dry, climate controlled environment.).
- Products sold by unauthorized dealers.
- Minor variations of color in cover materials against sample swatches or previous purchases.
- Minor irregularities of color, surface, grain, texture, wrinkles or stretch marks in natural leather.
- Fading or discoloration over time or due to soiling, staining, or dye-transferring from clothing.
- Labor costs associated with the installation of warrantied parts.
- Any damage not noted on the freight bill before signing at time of delivery

In no event shall the total liability of manufacturer resulting from product failure, as damages or otherwise, exceed the purchase price of the product. Neither Laacke and Joys Company LLC nor their authorized dealers under any circumstances shall assume responsibility for loss of time, inconvenience, commercial loss, expenses for travel, lodging, or damage to personal property, loss of revenue, or incidental or consequential damages.

Laacke and Joys Company LLC reserves the right to make changes or improvements in the design of Concept Seating products without obligation to make corresponding changes or improvements in previously manufactured Concept Seating products.

All warranty claims must be submitted using the online claim form at www.conceptseating.com/resources/warranty-claim/.

This is the exclusive and complete warranty made by Laacke and Joys Company LLC with respect to the Concept Seating 24/7 Intensive Use seating products. No person whatsoever is authorized to make any representation, warranty, or promise on behalf of the manufacturer. Laacke and Joys Company LLC makes no other expressed warranties and disclaims any and all implied warranties. The remedies set forth above pertaining to repair or replacement of parts or materials are exclusive of all other remedies. Dealer makes no warranty on his or her own.